

INTRODUCTION

The Aura 8 Advanced Flight Control System (AFCS) is a powerful, yet flexible flight control system. This Quick Start Guide provides you with basic information to help to get your airplane in the air for most aircraft. However, advanced aircraft and flight performance tuning may require additional programming using the Aura PC Programming Application.

To learn about the full capabilities of the Aura 8, as well as access the latest information and guides, please visit www.flexinnovations.com/aura.

CONNECTING A RECEIVER

The Aura 8 supports three separate connection methods - direct connection of up to (2) DSM2/DSMX remote receivers; data connection for Futaba S.Bus, JR XBus (Mode B), Graupner HOTT SUMD, Spektrum SRXL; and traditional PWM and PPM connections.

Quick Start programming only supports DSM2/DSMX remote receiver and serial bus/digital data feeds. Traditional PWM and PPM connections must be configured with the Aura Config Tool on a PC.

I. DSM2/DSMX Remote Receiver(s)

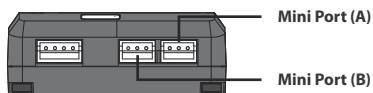

DSM2/DSMX Remote Receiver(s) Binding

1. A single remote receiver must always be connected to Mini Port 'A'. An additional remote receiver (optional, of matching type) may be plugged into Mini Port 'B'.
2. Insert a bind plug(s) in Port S8 on the Aura for DSMX remote receiver(s) OR into Ports S1 and S8 for DSM2 remote receivers.
3. Power the Aura with a 4.0VDC-10.0VDC power source. The LED on the remote receiver(s) will begin to blink rapidly indicating that the receiver(s) are in bind mode.
4. Put the transmitter in bind mode as described in the instructions in your transmitter manual. Binding is complete when the remote receiver LED is solid. Remove and store bind plug(s) to complete the binding process.

II. Serial Bus / Digital Data Receiver

Below are some representative examples of typical serial bus/digital data feed receivers from major manufacturers. Please note that any serial data/digital data feed receivers MUST be bound and properly setup in the transmitter prior to connecting to Aura. Consult your manufacturer documentation for proper methods and procedures to bind your receiver.

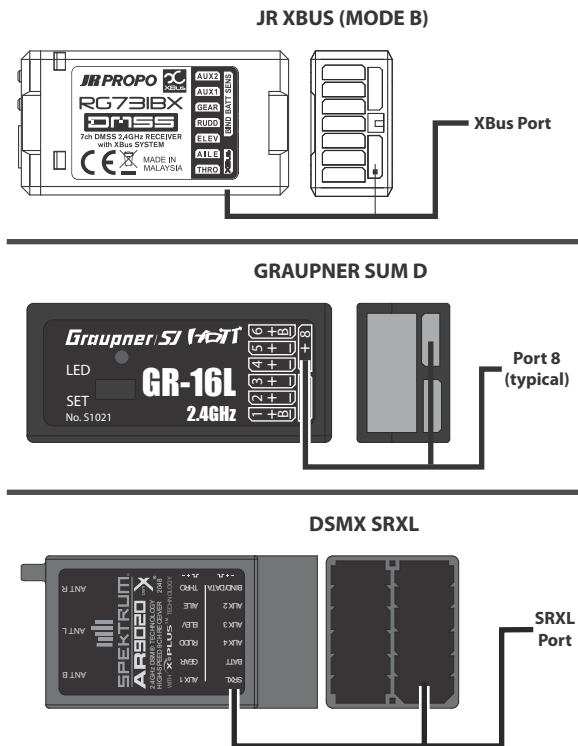
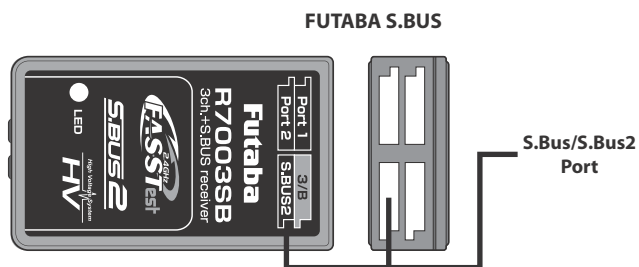

III. Traditional PWM or PPM

Traditional PWM and PPM receiver connections are supported with Aura but must be setup using the Aura PC Programming app and cannot be setup using the Radio Auto-Detect or Quick Setup method(s) detailed below.

POWERING AURA 8

Powering the Aura is very flexible. The Aura Servo Bus (S1 - S8 and Servo Port B) must be powered with 4VDC-10VDC. Simple electric models can power the Aura by plugging in the BEC directly to an Aura Servo Port. Power may also be passed directly from the Receiver to the Aura. More complex models may use additional connections or flight batteries for additional redundancy. Several examples are shown below. More examples can be found at www.flexinnovations.com/aura

WARNING

THE USER MUST PROVIDE AURA WITH A STABLE AND RELIABLE POWER SUPPLY. FAILURE TO DO SO COULD RESULT IN LOSS OF CONTROL OR CRASH.

Exercise extreme caution when plugging in any lead that could potentially supply power, or short power buses. It is possible to 'reverse' or 'short' a power connection by even partially plugging in a connector. Examples (but not limited to):

- Connecting multiple batteries or power leads. Use switches, extensions, and Y harnesses with extreme care.

Check the polarity of each connection carefully. Consult your radio manufacturer's manual for information regarding appropriate power supply connections.

DSM2/DSMX REMOTE RECEIVER(S) WITH ESC/BEC

The simplest setup is to provide system power through the ESC/BEC of an electric model. In the example below, the ESC/BEC is simply plugged into Aura Port S1, making note of the connection polarity.

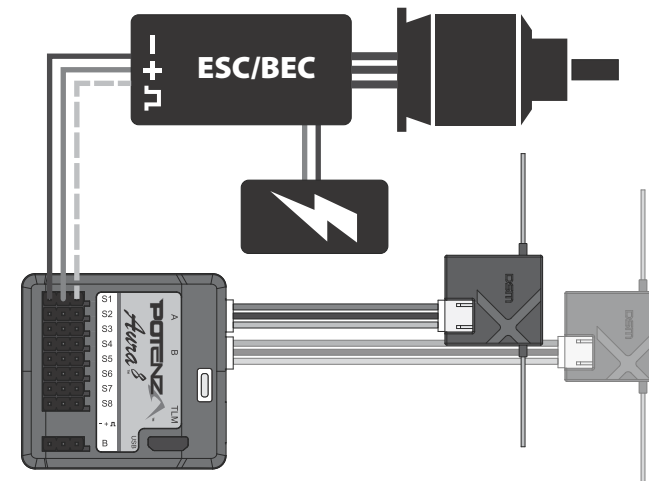

RECEIVER BATTERY POWER INPUT

If the aircraft is a larger electric or gas powered model, it may need a separate power source for the motor/engine. In this situation, a receiver battery can be connected directly to the receiver or the Aura. A matching redundant battery can optionally be added as shown. If there are not any open Aura ports, a battery may be connected to a servo port and servo using a Y harness.

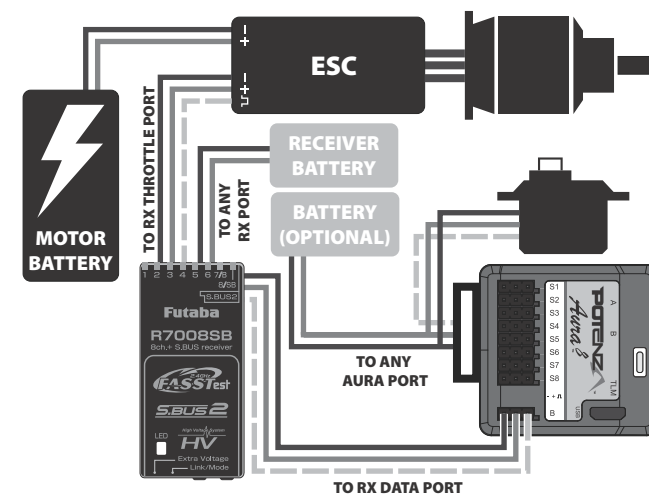

REDUNDANT DSM2/DSMX POWERSAFE SRXL POWER

For redundant power input using a DSM PowerSafe SRXL receiver, simply connect a two-wire lead from any servo port to any Aura port (S1-S8).

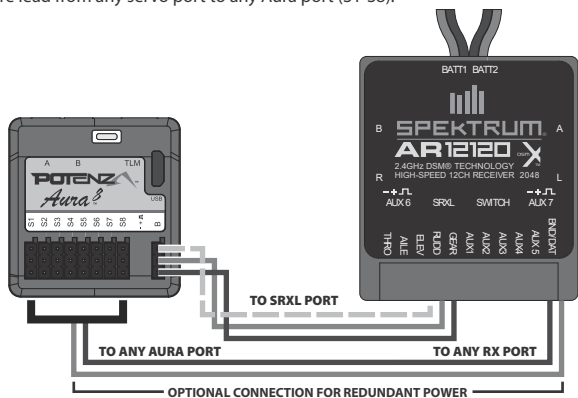

PARALLEL BATTERY POWER

If Aura has no additional ports available for battery power, parallel power may be supplied by plugging both a servo AND a battery into a single Aura port with a Y-harness. The signal wire should be removed from the 'power' lead in order to prevent any signal interference.

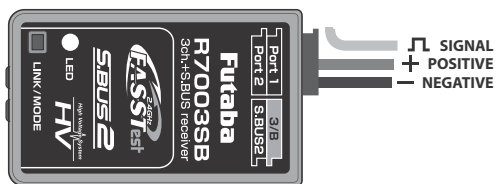

RADIO AUTO DETECT

Linking the Aura to the receiver is simple for supported radios. The Aura will Auto Detect the radio and adjust the correct input reversing (servos may still require reversal depending on the linkage geometry of that particular setup), channel order, etc. **Make sure your receiver is bound or linked to your transmitter.**

For Aura to receive digital channel data in the correct slots, transmitter Wing Type must be set to conventional (single aileron) and transmitter Tail Type must also be set to conventional (single elevator and rudder).

For retrofit setups in complex aircraft, it is necessary to change these values back to default values (as they are in a new/reset model memory): Wing Type, Tail Type, Servo Reversing. These changes should be made before Auto Detect has configured Aura to your receiver.

RADIO AUTODETECT WILL NOT DETECT TRADITIONAL PWM OR PPM CONNECTIONS.

1. Transmitter travel may be adjusted as required. **For good results, transmitter travel is expected to be between 90% and 140% with 125% being ideal.**
2. Make physical connections per the connection diagrams in CONNECTING A RECEIVER.
3. With the propeller removed (on electric models) and all Aura connections in place, power on your transmitter, then power your airplane with the flight battery and keep it stationary. After several seconds, the LEDs will sweep back and forth as the Aura searches for a valid control signal. Once found, you will see a solid orange (Aura and sensors are running) and a solid green (Aura is receiving a valid signal) LED, and you will have control of the model.

AURA LED LIGHT LAYOUT

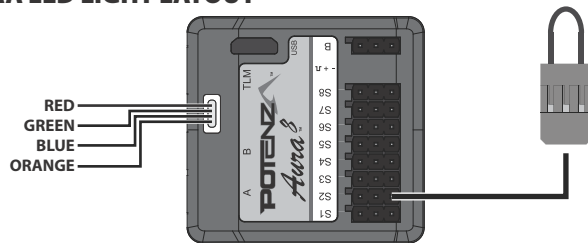

CONFIGURE AURA

The Aura must be configured to properly set the servo ports (S1 - S8), gyro gain, etc.

Complex aircraft should be configured using the Aura PC Programming App, however, many airplanes can be configured at the field with only a transmitter using the Aura Quick Setup feature. To use the Quick Setup feature, the airplane must meet the following criteria:

1. Digital receiver data feed, including any of these:
 - DSM2/DSMX Remote Receivers or SRXL connection
 - Futaba S. Bus
 - JR DMSS XBus (Mode B)
 - Graupner HOTT SUM D of 8
2. Conventional tail type (single elevator/rudder servo or matched pair with single input) OR dual elevator servos with reversed mounting direction for each servo.
3. Conventional wing type using one or two aileron servos (or more if one or two inputs are used with Y-harnesses or servo matching device such as JR MatchBoxes)
4. Aura mounted with Mini Ports A & B oriented towards the nose of the aircraft. Pins for Ports S1-S8 may be oriented upright or inverted. (see instructions below)
5. CH5/Gear assigned to a 3-position switch (preferred) on the transmitter. A 2-position switch may be used, but Aura will be limited to (2) flight modes.

If your airplane adheres to the criteria above, follow the steps below to setup your airplane with the Aura 8 quickly at the field using Quick Setup mode and your transmitter.

Quick Setup mode is not recommended for retrofitting your Aura 8 into complex aircraft such as those with multiple servo wing types or flaps. The Aura PC Config Tool is more flexible and effective for complex aircraft.

AURA QUICK SETUP (VIA TRANSMITTER)

Quick Setup Servo Connections

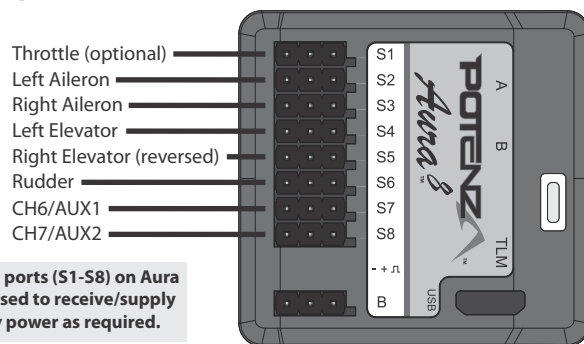

Any open ports (S1-S8) on Aura may be used to receive/supply battery power as required.

NOTICE

If only one aileron servo is being used, it should be connected into Port S3. If only one elevator servo is being used, it should be connected into Port S4.

WARNING

DO NOT ATTEMPT RADIO SETUP WITH PROPELLER INSTALLED. INADVERTENT POWER UP COULD CAUSE PERSONAL INJURY.

CAUTION

While there is no throttle signal present in quick configuration, keep the throttle fully idle during setup to avoid damage or injury.

Entering Quick Setup Mode

1. Turn on transmitter. With the throttle low, center the aileron/elevator/rudder sticks.
2. Insert bind plug into **Aura Port S2**.
3. Apply power to Aura and receiver.

If Aura has not detected the radio system being used, Auto-Detect will run, then Quick Setup will begin. If you did not intend to enter Quick Setup Mode, remove power BEFORE unplugging the bind plug to prevent any changes from being saved. Steps 1 & 2 may be adjusted back and forth in any order before continuing to Step 3 & 4 and saving in Step 5. **The orange LED will flash in Quick Setup Mode. The blue, green, and red LEDs will illuminate to correspond to the current settings being set in Quick Setup.**

1. Setting Model Type

Two model types can be selected with pre-configured profiles that have been crafted over hundreds of test flights. CH5/Gear switch is used to toggle the model type; high position will select Sport/Scale Mode and low position will select 3D Mode. Check the green LED (second from the right) to confirm you have selected the desired model type.

LED Indication

Green LED On - Sport/Scale Mode
Green LED Off - 3D Mode

2. Enabling Master Gain (Optional)

Requires a transmitter proportional input assigned to transmitter CH8/Aux3

Master Gain is OFF upon each entry to Quick Setup Mode. Master Gain on **CH8/Aux3** may be enabled by sweeping the **CH8/Aux3 knob or slider**. Check the RED LED (at the far right) to confirm you have master gain set as intended. **If no adjust is made, master gain will remain disabled.**

LED Indication

Red LED On - Master Gain Enabled
Red LED Off - Master Gain Disabled

3. Setting Orientation

Two orientations are available in Quick Setup mode: 'Pins Up' and 'Pins Down'. Both orientations must have Mini Ports A and B toward the nose of the aircraft. The Aura must be aligned coincident to the axes of aircraft as shown below. After completing steps 1 and 2 above, place the Aura in the orientation it will be in upright flight before proceeding to Step 4. Check the Blue LED to confirm the intended orientation.

LED Indication (with aircraft right-side up)

Blue LED On - Aura Normal orientation (pins up)
Blue LED Off - Aura Inverted orientation (pins down)

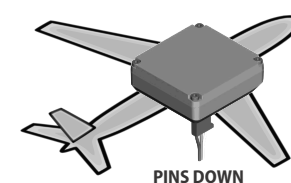
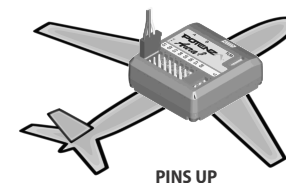

4. Reversing Servo Direction

1. Perform the transmitter command check to verify control surface movement corresponds to the control direction test chart below.
2. If reversing is required on aileron, elevator, or rudder, hold full stick deflection for that channel in any direction for a minimum of four seconds, at which point the channel will reverse. This process may be repeated as required for each channel. Servo reversing changes are saved automatically.

Throttle is not reversible in the Aura. If your model requires throttle channel reversing, it must be done in the transmitter.

	Transmitter Command	Proper Control Surface Deflection
AILERON	Stick Left	
	Stick Right	
ELEVATOR	Stick Forward	
	Stick Aft	
RUDDER	Stick Left	
	Stick Right	

5. Saving Quick Setup Settings

With the aircraft upright, remove the bind plug from Aura Port S2 to save the settings from Steps 1-4. All the LEDs will go solid will saving, then return to normal after the save is complete. If saving the settings for these steps is not desired, remove power before removing the bind plug.

6. Sensor Check

Rotate the airplane about each axis, 15° minimum. Use sensor check diagram below to verify that control surface moves in the correct direction to counter the motion. During Quick Setup mode, a special control mode executes and makes checking the sensor direction easier. Moving the sticks will reset the control surfaces to center, if required.

	Aircraft Movement	Proper Control Surface Deflection
AILERON		
ELEVATOR		
RUDDER		

In Quick Setup mode step 6, if the airplane and transmitter are left unattended for a period of time, the sensor may accumulate errors and may move the control surfaces. Simply move the transmitter sticks to reset. **NOTE: This only happens in the Quick Setup mode and will NOT occur in normal (flying) mode.**

If any of the axes fail the control sensor check but responds correctly to the transmitter commands, check the transmitter's programming and ensure that all the directions are set to NORMAL. Repeat the transmitter command test and sensor check until all surfaces move as intended.

7. Exiting Quick Setup Mode

Exit Quick Setup mode by removing power from the Aura. Confirm the bind plug has been removed from S2 prior to repowering the Aura. **You must power down the Aura to exit Quick Setup mode before flying.**

Repeat all control direction and sensing direction tests in normal mode (in highest gain setting) before flying. If any anomalies exist, correct before attempting flight.

QUICK TRIM

The Aura 8 features a Quick Trim Mode that eliminates the need for mechanical linkage adjustments during test flights. Aura will learn the trim values and apply them to the control surfaces at power up when enabling quick trim mode. While it is always best to mechanically trim your aircraft so no transmitter trims are required, sometimes electronic trim is unavoidable.

NOTE: Quick trim can also be used BEFORE flying to make small changes to center the control surfaces before flight.

To setup Quick Trim:

1. Fly the airplane in manual (gyro off) mode. Trim the aircraft with the transmitter and land. Do not change flight modes.
2. Power off the Aura. Insert a bind plug into Aura Port S3. Check the transmitter is on and re-power the Aura.
3. Wait 5 seconds for the Aura to completely initialize. Confirm Quick Trim mode is active by checking the Blue LED is slowly flashing.
4. Remove the bind plug from Aura Port S3. Removing the bind plug stores the current trims in the Aura. The Blue LED will flash quickly after control surface trim values are stored. While the trim values are stored in Aura, they are not applied to the control surface until the Aura is re-powered.
5. Remove power from the Aura and center all control surface trims on the transmitter.

NOTE: QUICK TRIM MAY BE REPEATED AS NEEDED FOR FINE TUNING, OR IF CHANGES TO THE AIRCRAFT ARE MADE.

NOTE: ENSURE AILERON/ELEVATOR/RUDDER SUB TRIMS ARE ZERO BEFORE FLYING FOR QUICK TRIM PROCESS.